

# Enterprise 9000X

## Opuszczanie segmentu oparcia pleców do funkcji CPR

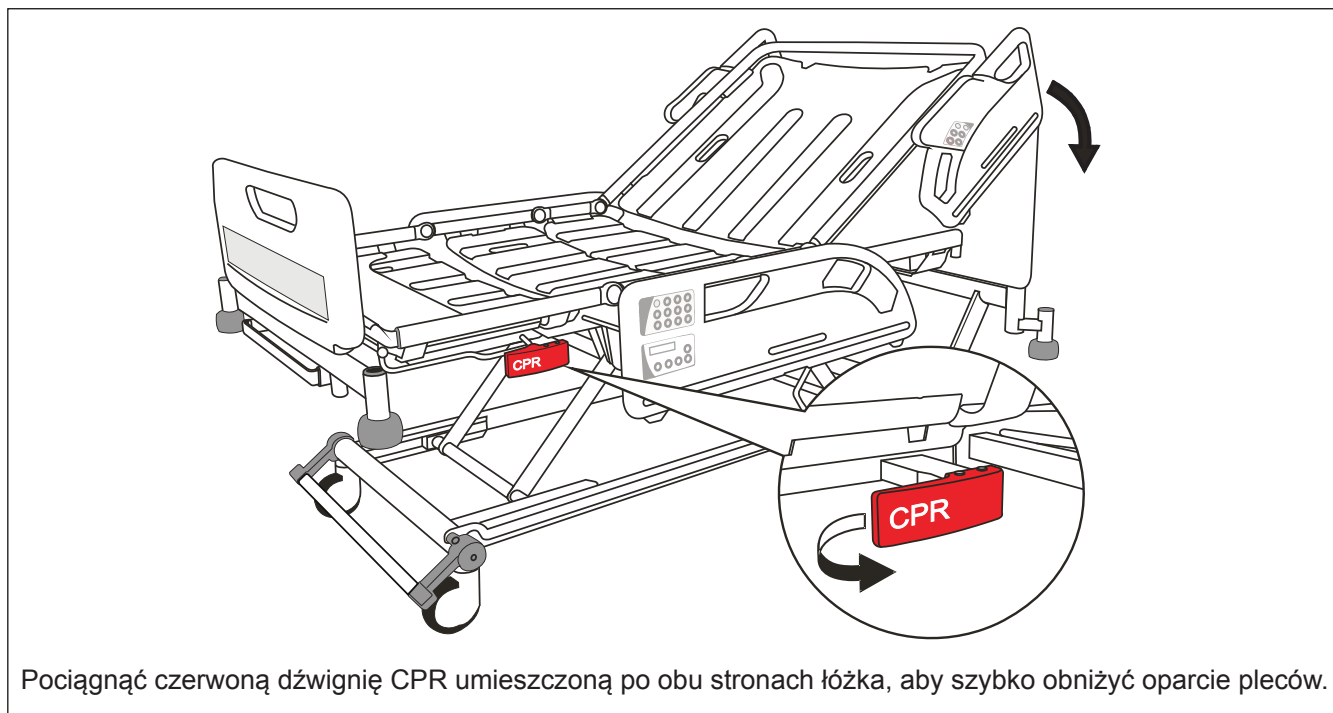

## Hamulce i sterowanie

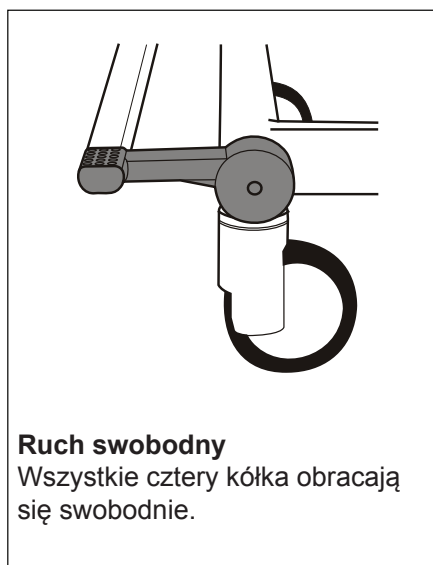
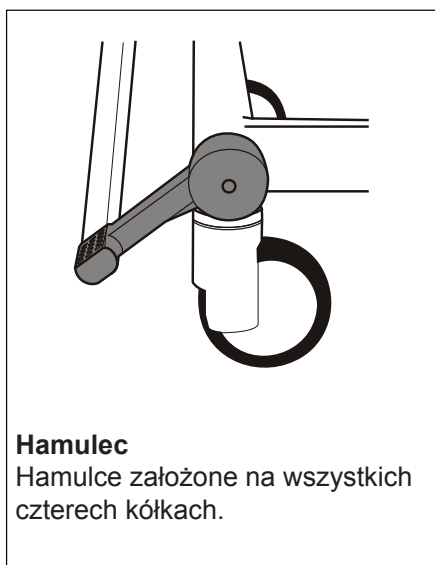

Hamulce powinny być założone zawsze, kiedy łóżko stoi w miejscu.

## Barierki boczne

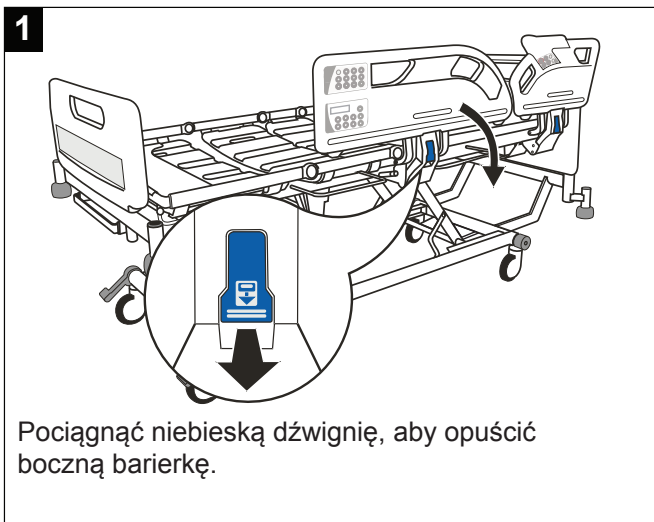

## Regulacja długości łóżka (trzy nastawy)

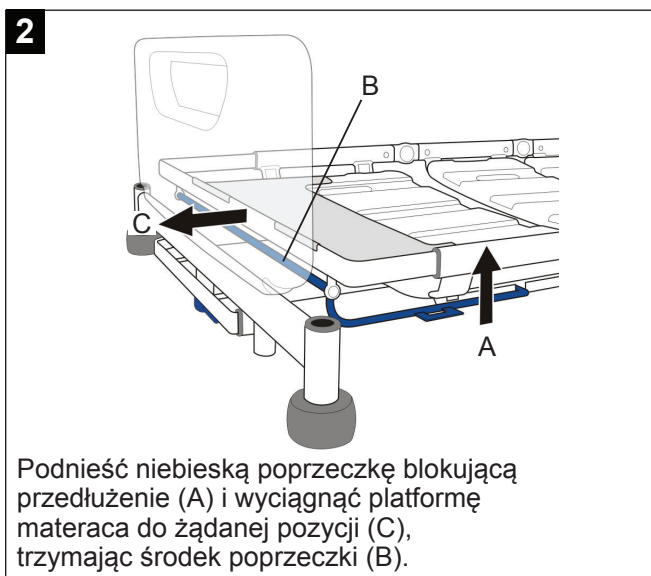
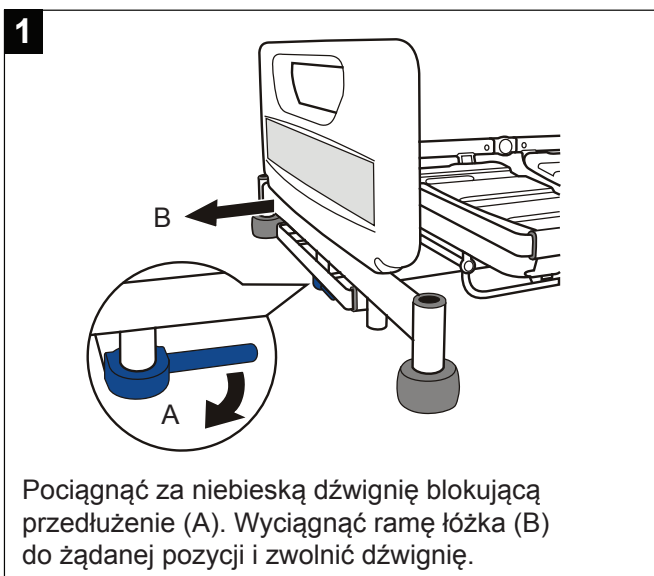

## Regulacja segmentu podparcia łydek

